

D500



D500 Gage Controller

Accuracy, flexibility and power for demanding gaging applications

For more than 35 years Control Gaging Inc. has been tackling the constantly evolving measurement needs of world-class machine tool builders and component manufacturers.

Building from our expanding reservoir of software features, and taking advantage of the latest hardware, the D500 Gage Controller advances the art of process control. Whether your requirement is multi-feature, automatic-changeover grinder control or complex inspection-with-feedback, the D500 can be configured to meet your needs.

A unique Windows-based interface provides operators with full navigation and execution from a simplified keypad. The color LCD screen can be configured to display multiple gage meters with I/O and process indicators for each. A USB mouse and keyboard can also be connected for special interface needs.

In keeping with Control Gaging's worldwide reputation for durability, the D500 is built of factory-hardened components and housed in a sturdy metal enclosure. The D500 is backed by a two-year warranty.



- Simple keypad interface
- Smooth or interrupted surfaces
- In-process or post-process applications
- SPC / Data Storage
- Up to 8 LVDT inputs
- 8 Inputs/24 Outputs
- 2440 readings/sec.
- Data transfer to USB memory stick
- RoHS Compliant

Innovative use of advanced DSP technology gives a stable, sub-micron data stream for the software to process. And experienced Control Gaging field and software engineers have been working closely together for years to create powerful, reliable techniques for dynamic workpiece measurement and for process improvement on the factory floor. The result is a uniquely capable product for a wide spectrum of close-tolerance applications.

Optional Hardware and Software Features

- | | |
|-----------------------------------|-----------------------------|
| BCD/binary outputs | Panel mount |
| Diverter control | Part counter |
| Grindline control | Proportional analog output |
| Intelligent Process Control (IPC) | Remote compensation |
| Language selection | Remote zeroing |
| Locator outputs | Profiling/Part shape |
| Multi-channel zeroing | Stock removal preset |
| Multi-Part selection | Taper |
| Multi-diameter selection | "Wide-range gaging" to 25mm |
| Out-of-round/Runout | ...and more |

TAKE CONTROL & SAVE MONEY

Control Gaging Incorporated

847 Avis Dr. Ann Arbor, Michigan 48108 Phone: +1 734.668.6750 Fax: +1 734.994.1335
www.controlgaging.com Email: sales@controlgaging.com

D500



D500 Chassis Dimensions - Standard, Panel Mount, and Remote Panel

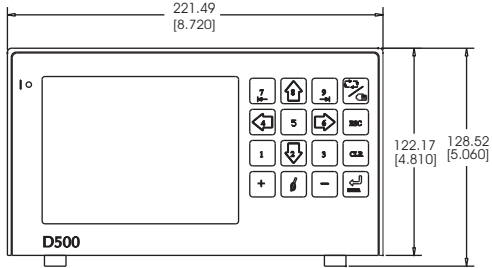

FRONT VIEW - Standard Enclosure

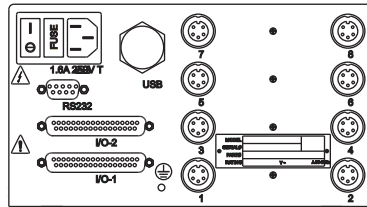

REAR PANEL - Standard and Panel Mount

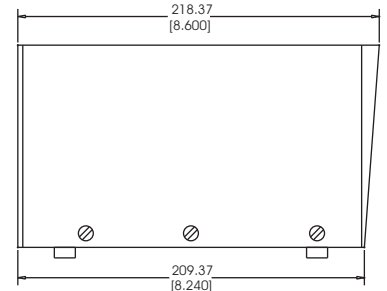

LEFT SIDE VIEW- Standard

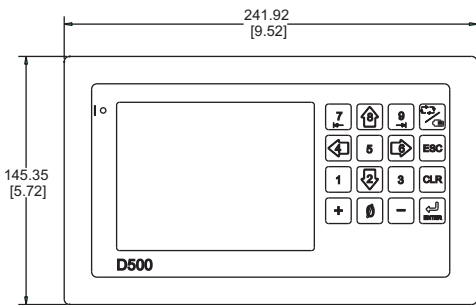

FRONT VIEW - Panel Mount Chassis

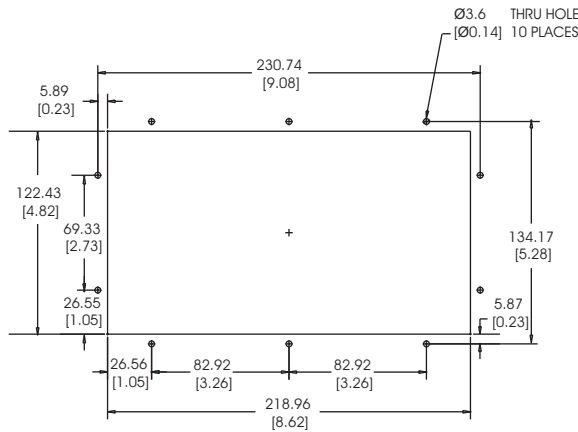

PANEL CUTOUT - Panel Mount

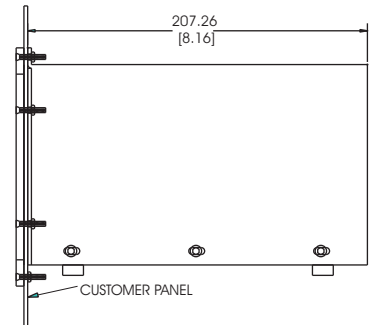

RIGHT SIDE- Panel Mount

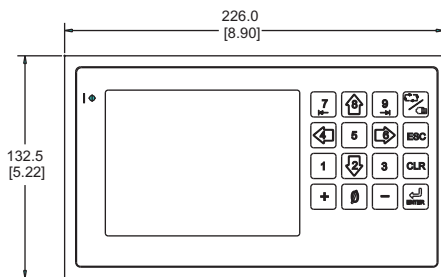

FRONT VIEW - Remote Panel Chassis

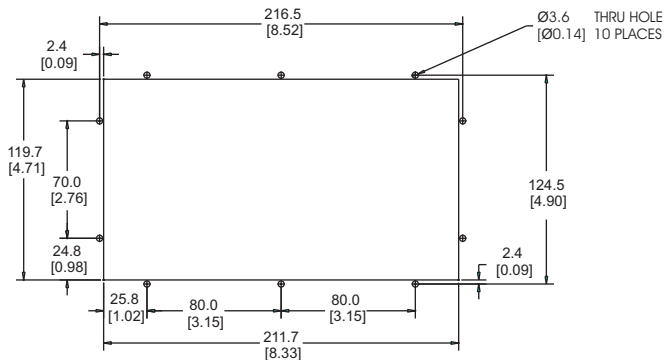

PANEL CUTOUT - Remote Panel

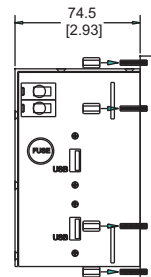

LEFT SIDE VIEW- Remote Panel

General Specifications

Weight: 2.3kg. (5.0 lbs.)
Chassis: IP54

Power: 100-240V ac
 50/60 Hz,
 21W

Inputs: 20-30V dc
Outputs: 24V dc
 125 mA max.

TAKE CONTROL & SAVE MONEY

Control Gaging Incorporated

847 Avis Dr. Ann Arbor, Michigan 48108 Phone: +1 734.668.6750 Fax: +1 734.994.1335
 www.controlgaging.com Email: sales@controlgaging.com